

PART NUMBER	COLOR
3001509001	BLACK
3001509002	RED
3001509003	YELLOW CHEDDAR
3001509004	AMERICAN BLUE
3001509005	ORANGE SHARP CHEDDAR
3001509006	WHITE
3001509007	LIGHT BLUE (TURQUOISE)
3001509008	GREEN
3001509009	LIGHT AMERICAN BLUE
3001509012	TERRA COTTA

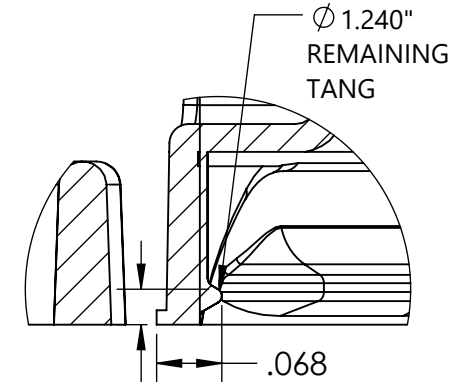
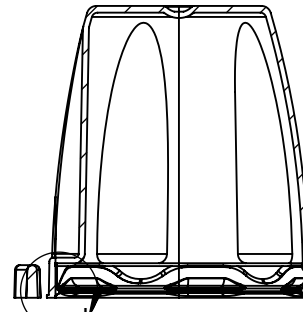
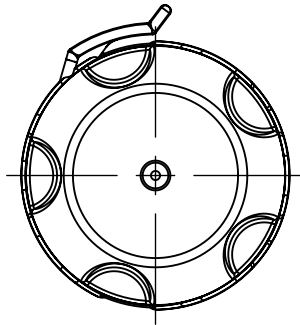

SECTION H-H

.037  
.068

DETAIL J  
SCALE 5 : 1

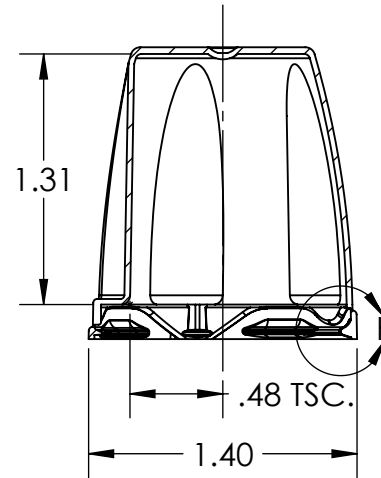
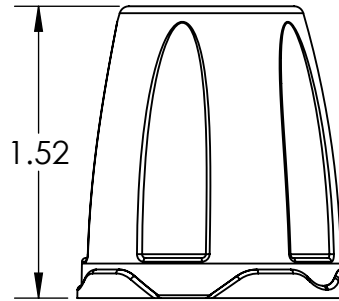
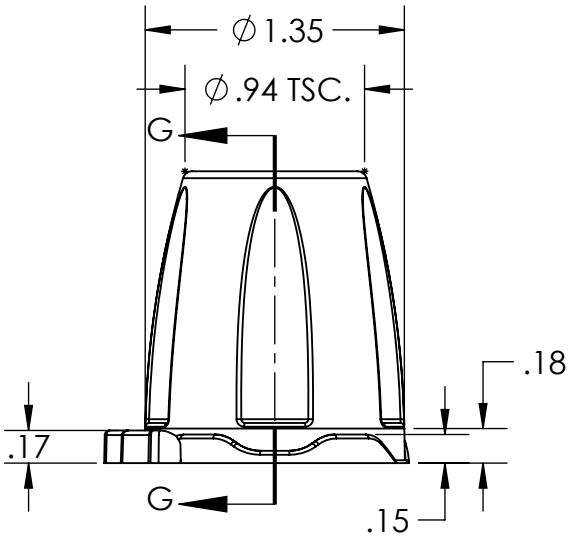

SECTION G-G

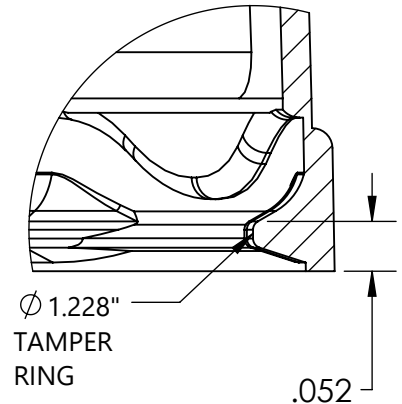

DETAIL K  
SCALE 5 : 1

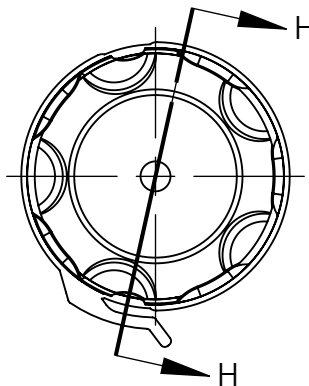
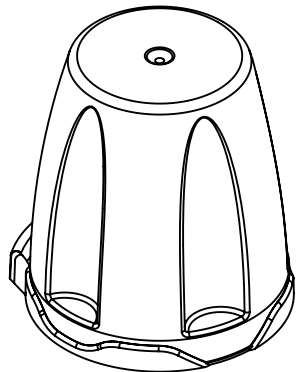

**PROPRIETARY AND CONFIDENTIAL**  
THE INFORMATION CONTAINED IN THIS DRAWING IS THE SOLE PROPERTY OF CLAYTON CORPORATION. ANY REPRODUCTION IN PART OR AS A WHOLE WITHOUT THE WRITTEN PERMISSION OF CLAYTON CORPORATION IS PROHIBITED.



866 HORAN DR.,  
FENTON, MO 63026  
636-349-5333

DRAWN BY:		NAME	DATE	TITLE:	
KRM		KRM	5/29/15	TE509 Cover	
CHECKED BY:			3/18/09	SIZE	REV C
Tolerances:		DECIMAL INCHES: 0.0 +/- .015" 0.00 +/- .010" 0.000 +/- .005"		A	PART # 30012090XX
ANGULAR: +/- .10 DEG.					MATERIAL: Olefin Polymer
				SCALE: 1:1	SHEET 1 OF 2



866 Horan Drive  
 Fenton, MO 63026 USA  
 1-800-729-8220  
 1-636-349-5333  
 www.claytoncorp.com

**SPECIFICATION SHEET**  
**TE509 Cover**

Cover Part Number: 30012090XX

**Cover Information:**

Parameter	Information
Food Grade	Yes
Weight†	English: 0.11 oz.; Metric: 3.2 g
Material	Olefin Polymer
Appearance	Variable

**Carton Information:**

Item	English	Metric
Quantity	2,250	2,250
Size	L: 23 in. x W: 15 in. x H: 18 in.	L: 58.4cm x W: 38.1cm x H: 45.7cm
Weight†	18.6 lbs.	8.4 kg

**Pallet Information:**

Item	USA	International
Style	USA	USA
Quantity	45,000	22,500
Size	L: 40 in. x W: 48 in. x H: 78 in.	L: 101.6cm x W: 121.9cm x H: 106.7cm
Weight†	412 lbs.	102 kg

**Warehouse Storage Information:**

Condition	English	Metric
Location	Dry Protected Area	Dry Protected Area
Temperature	40°F — 100°F	4.4°C — 37.8°C
Time	Up to 5 years	Up to 5 years

† Weights are approximates

Approved By: Brennan Fogarty

Date: 10/5/2021