

PART NUMBER	MATERIAL
3001260159	HD POLYETHELENE WHITE
3001260160	HD POLYETHELENE NATURAL

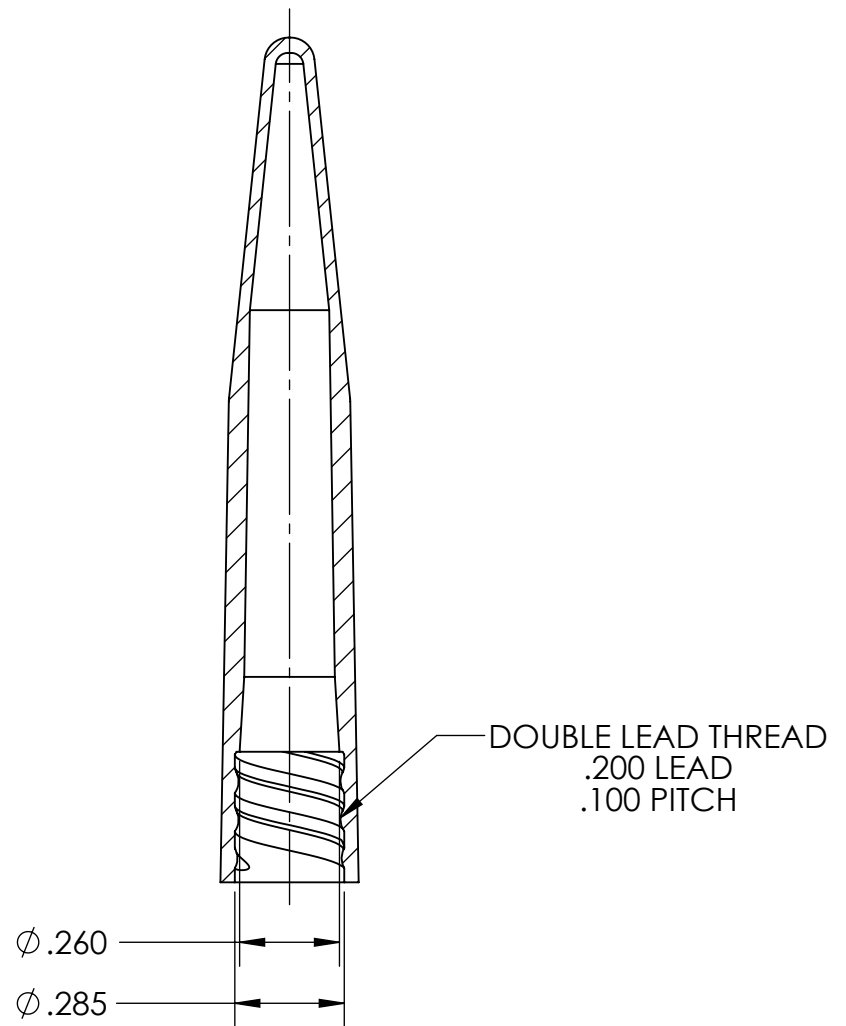

SECTION A-A

PROPRIETARY AND CONFIDENTIAL
 THE INFORMATION CONTAINED IN THIS DRAWING IS THE SOLE PROPERTY OF CLAYTON CORPORATION. ANY REPRODUCTION IN PART OR AS A WHOLE WITHOUT THE WRITTEN PERMISSION OF CLAYTON CORPORATION IS PROHIBITED.

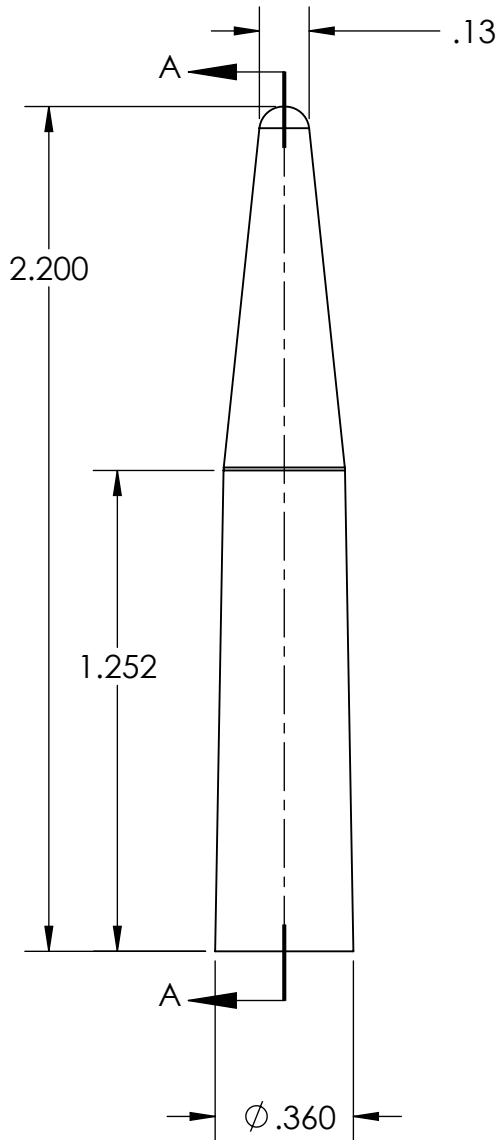

866 HORAN DR.,
 FENTON, MO 63026
 636-349-5333

	NAME	DATE	TITLE:	
DRAWN BY:	DGS	8/24/09	Dispensing Tip Short	
CHECKED BY:			SIZE	REV D
Tolerances:			A	
DECIMAL INCHES: 0.0 +/- .015"			PART #	
0.00 +/- .010"			30012601XX	
0.000 +/- .005"			MATERIAL:	
ANGULAR: +/- .10 DEG.			Olefin Polymer	SCALE: 2:1
				SHEET 1 OF 2



866 Horan Drive
 Fenton, MO 63026 USA
 1-800-729-8220
 1-636-349-5333
 www.claytoncorp.com

SPECIFICATION SHEET
Dispensing Tip Short

Component Part Number: 30012601XX

Component Information:

Parameter	Information
Food Grade	Yes
Weight†	English: 0.04 oz.; Metric: 1.1 g
Material	Olefin Polymer
Appearance	White/Clear

Carton Information:

Item	English	Metric
Quantity	10,000	10,000
Size	L: 20 in. x W: 11 in. x H: 14 in.	L: 50.8cm x W: 27.9cm x H: 35.6cm
Weight†	27.4 lbs.	12.4 kg

Pallet Information:

Item	USA	International
Style	USA	USA
Quantity	320,000	240,000
Size	L: 40 in. x W: 48 in. x H: 62 in.	L: 101.6cm x W: 121.9cm x H: 121.9cm
Weight†	917 lbs.	317 kg

Warehouse Storage Information:

Condition	English	Metric
Location	Dry Protected Area	Dry Protected Area
Temperature	40°F — 100°F	4.4°C — 37.8°C
Time	Up to 5 years	Up to 5 years

† Weights are approximates

Approved By: Brennan Fogarty

Date: 9/15/2021