

PART NUMBER	COLOR
1009000142	BLUE
1009000143	WHITE
1009000144	RED
1009000145	NATURAL

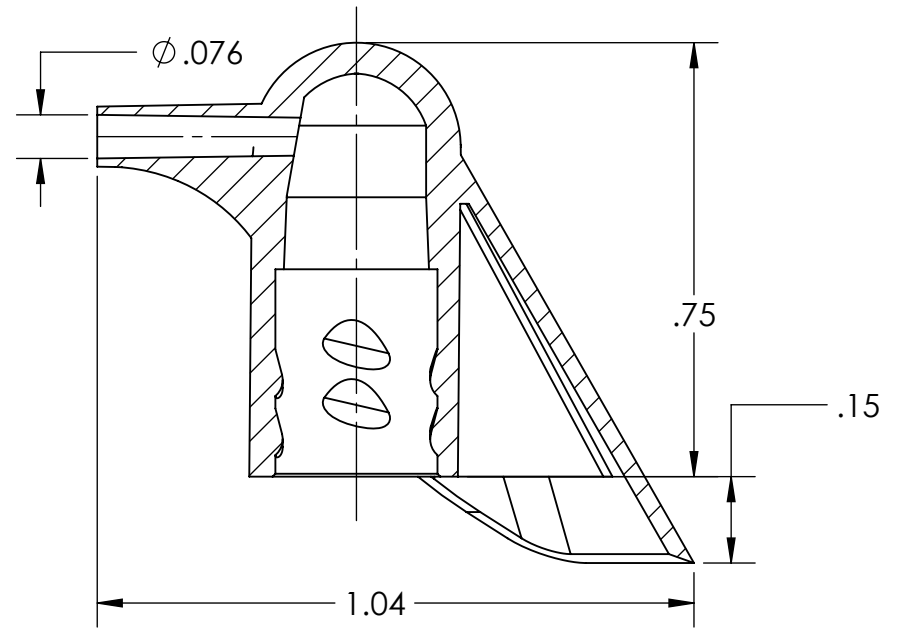

SECTION H-H

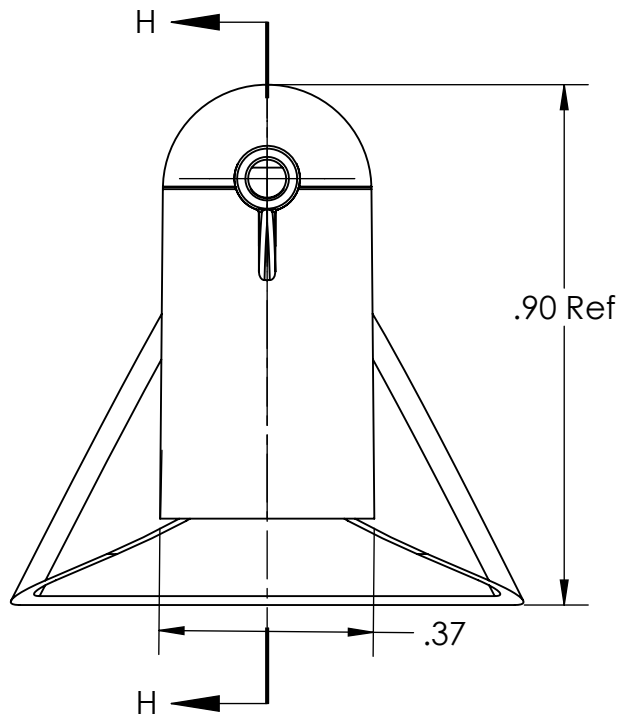
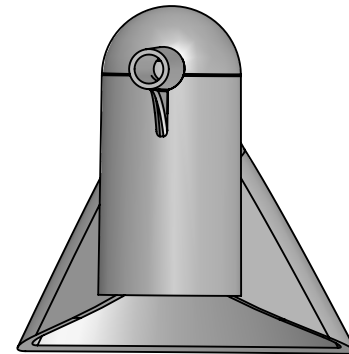
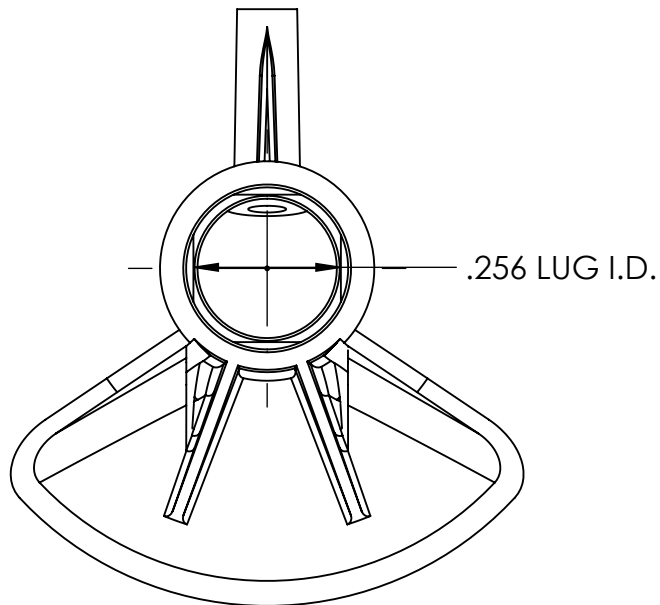

PROPRIETARY AND CONFIDENTIAL
 THE INFORMATION CONTAINED IN THIS
 DRAWING IS THE SOLE PROPERTY OF
 CLAYTON CORPORATION. ANY
 REPRODUCTION IN PART OR AS A WHOLE
 WITHOUT THE WRITTEN PERMISSION OF
 CLAYTON CORPORATION IS PROHIBITED.



866 HORAN DR.,
 FENTON, MO 63026
 636-349-5333

		NAME	DATE	TITLE:	
DRAWN BY:		Admin	10/12/2017	Darth Nozzle	
CHECKED BY:					
Tolerances:		DECIMAL INCHES: 0.0 +/- .015" 0.00 +/- .010" 0.000 +/- .005"		SIZE	REV A
		ANGULAR: +/- .10 DEG.		A	
				PART #	
				MATERIAL:	
				Olefin Polymer	
				SCALE: 3:1	SHEET 1 OF 2



866 Horan Drive
Fenton, MO 63026 USA
1-800-729-8220
1-636-349-5333
www.claytoncorp.com

SPECIFICATION SHEET

Darth Nozzle

Component Part Number: 100900014X

Component Information:

Parameter	Information
Food Grade	Yes
Weight†	English: 0.03 oz.; Metric: 1.0 g
Material	Olefin Polymer
Appearance	Variable

Carton Information:

Item	English	Metric
Quantity	10,000	10,000
Size	L: 20 in. x W: 11 in. x H: 14 in.	L: 50.8cm x W: 27.9cm x H: 35.6cm
Weight†	24.1 lbs.	10.9 kg

Pallet Information:

Item	USA	International
Style	USA	USA
Quantity	320,000	240,000
Size	L: 40 in. x W: 48 in. x H: 62 in.	L: 101.6cm x W: 121.9cm x H: 121.9cm
Weight†	812 lbs.	281 kg

Warehouse Storage Information:

Condition	English	Metric
Location	Dry Protected Area	Dry Protected Area
Temperature	40°F — 100°F	4.4°C — 37.8°C
Time	Up to 5 years	Up to 5 years

† Weights are approximates

Approved By: _____

Brian Fogarty

Date: 9/17/2021