

SECTION A-A  
SCALE 3 : 1

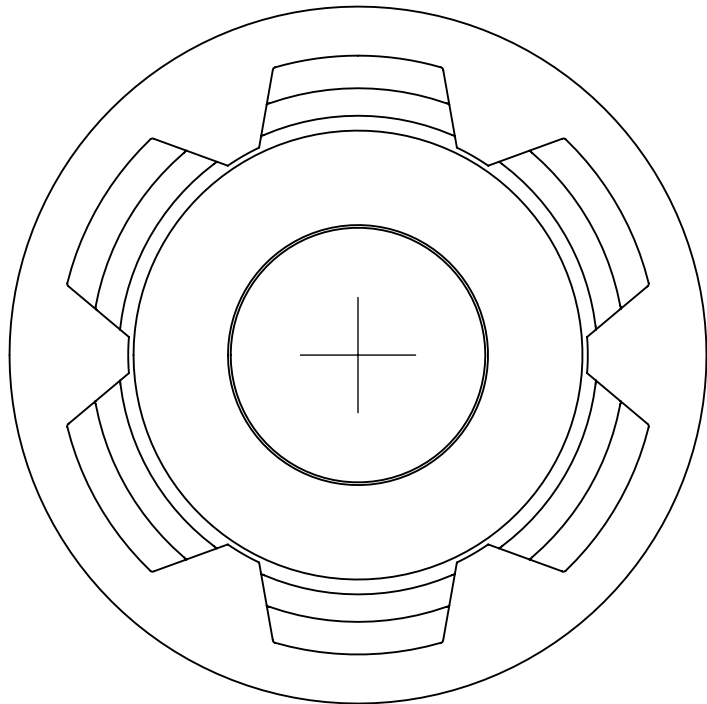

**PROPRIETARY AND CONFIDENTIAL**  
THE INFORMATION CONTAINED IN THIS DRAWING IS THE SOLE PROPERTY OF CLAYTON CORPORATION. ANY REPRODUCTION IN PART OR AS A WHOLE WITHOUT THE WRITTEN PERMISSION OF CLAYTON CORPORATION IS PROHIBITED.



866 HORAN DR.,  
FENTON, MO 63026  
636-349-5333

DRAWN BY: JPM		DATE: 1/28/08	TITLE: Caulk Lock	
CHECKED BY:		10/13/09	SIZE: A	REV B
Tolerances:		DECIMAL INCHES: 0.0 +/- .015" 0.00 +/- .010" 0.000 +/- .005"	PART #: 3003061011	SHEET 1 OF 2
ANGULAR: +/- .10 DEG.			MATERIAL: Olefin Polymer	SCALE: 2:1



866 Horan Drive  
 Fenton, MO 63026 USA  
 1-800-729-8220  
 1-636-349-5333  
 www.claytoncorp.com

**SPECIFICATION SHEET**  
**Caulk Lock**

Component Part Number: 3003061011

**Component Information:**

Parameter	Information
Food Grade	No
Weight†	English: 0.08 oz.; Metric: 2.3 g
Material	Olefin Polymer
Appearance	White

**Carton Information:**

Item	English	Metric
Quantity	2,500	2,500
Size	L: 20 in. x W: 11 in. x H: 14 in.	L: 50.8cm x W: 27.9cm x H: 35.6cm
Weight†	15.3 lbs.	7.0 kg

**Pallet Information:**

Item	USA	International
Style	USA	USA
Quantity	80,000	60,000
Size	L: 40 in. x W: 48 in. x H: 62 in.	L: 101.6cm x W: 121.9cm x H: 121.9cm
Weight†	531 lbs.	185 kg

**Warehouse Storage Information:**

Condition	English	Metric
Location	Dry Protected Area	Dry Protected Area
Temperature	40°F — 100°F	4.4°C — 37.8°C
Time	Up to 5 years	Up to 5 years

† Weights are approximates

Approved By: Brennan Fogarty

Date: 1/10/2023